

### TWEETER

### 19TFF

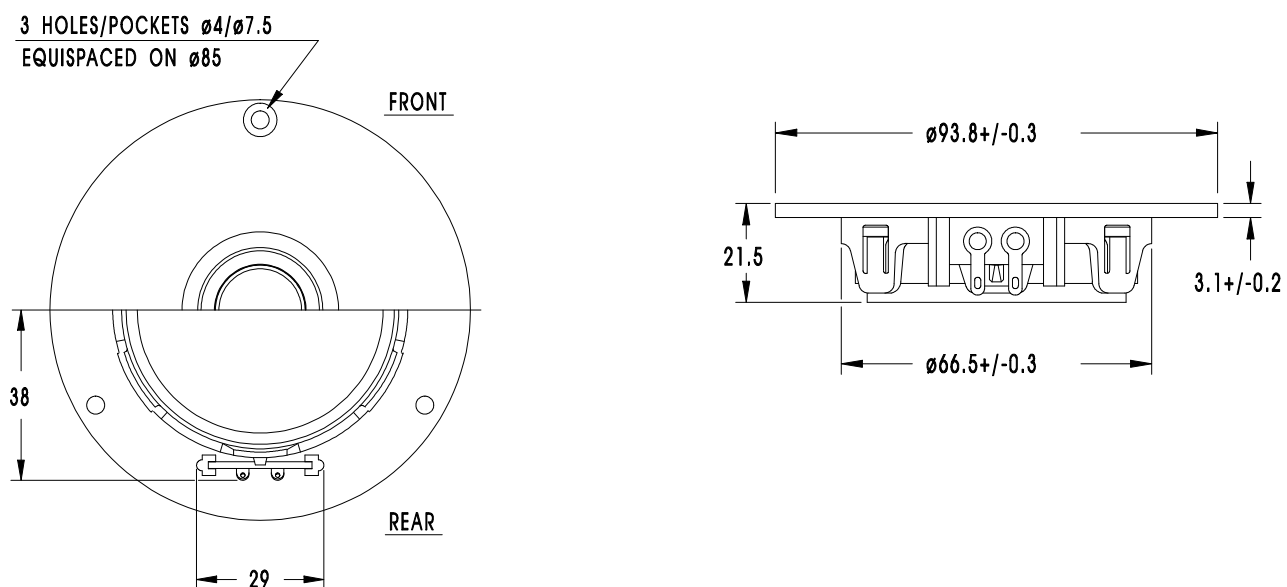

19mm High Fidelity dome tweeter with extremely smooth frequency response. The chassis is injection moulded in high grade glass fibre reinforced plastic. The diaphragm is made from a precoated fabric using an unique production method developed by SEAS. The precoating allows very tight production tolerances and high consistency. The diaphragm is suspended by a soft polyamide surround which allows for a low fundamental frequency. The combination of plastic surround and fabric diaphragm in carefully matched shapes, results in improved frequency response and dispersion compared to standard one piece soft domes. The voice coil is wound on an aluminium voice coil former with ventilating holes which eliminate problems connected with resonances in the internal cavities. The voice coil windings are immersed in magnetic fluid to increase short term power handling capacity, to reduce the compression at high power levels and to significantly reduce the Q factor.

#### NOTES

Response curve recorded in an anechoic chamber (Free-field, 4 pi radiation) with 0.5m microphone distance. The loudspeaker is mounted in a 0.6m by 0.8m baffle.

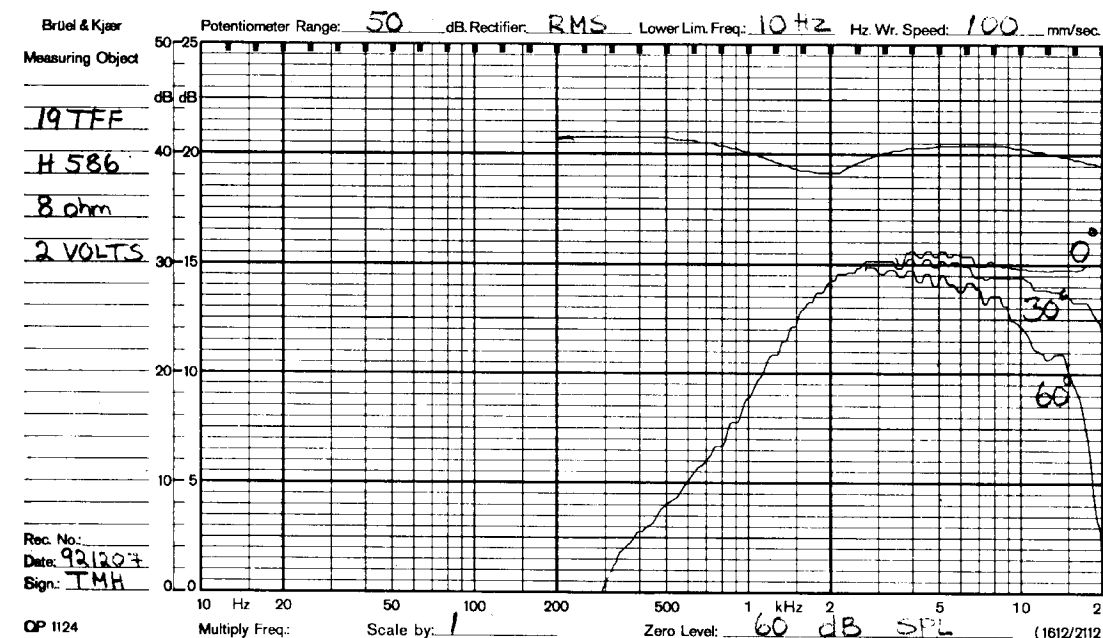

Cumulative spectral decay

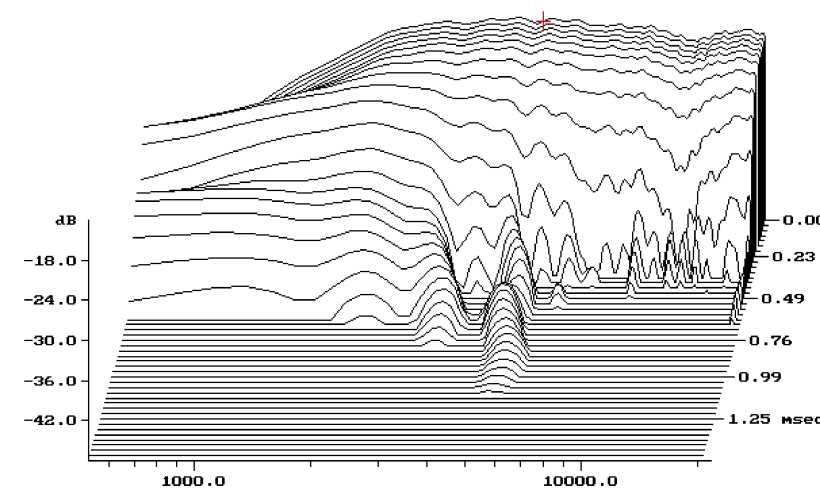

NOMINAL IMPEDANCE	8 Ohms	VOICE COIL RESISTANCE	6.2 Ohms
RECOMMENDED FREQUENCY RANGE	4000-20000 Hz	VOICE COIL INDUCTANCE (EQUIVALENT)	0.05 mH
SHORT TERM MAXIMUM POWER*	200 W	VOICE COIL DIAMETER	19.5 mm
LONG TERM MAXIMUM POWER*	80 W	VOICE COIL HEIGHT	1.5 mm
CHARACTERISTIC SENSITIVITY (1W, 1m)	87 dB SPL	MOVING MASS	0.22 g
OPERATING POWER (96 dB SPL, 1 m)	8.0 W	EFFECTIVE PISTON AREA	4.0 sq.cm
		LINEAR COIL TRAVEL (p-p)	0.5 mm
AIR GAP HEIGHT	2.0 mm	FREE AIR RESONANCE	1700 Hz
MAGNETIC GAP FLUX DENSITY	1.4 T		
FORCE FACTOR	2.6 N/A		
MAGNET WEIGHT	0.12 Kg		
TOTAL WEIGHT	0.30 Kg		

\* IEC 268-5, VIA HIGH PASS BUTTERWORTH FILTER: 5000 Hz 12 dB/oct.