

## Wom180\_vMS

High quality mid-woofer



Wom180\_vMS is a high-quality mid-woofer engineered to be used in 2 ways demanding system, with affordable sensitivity. We recommend to use this driver to cover the bandwidth from 40Hz to 2500Hz (-3dB).

It has been engineered to provide accurate cone movements, with +/-8mm real linear excursion.

The powerful motor structure is based on advanced pole piece geometry which focus 1.3T in the gap, long cooper ring, keeping smooth inductance ( $L_e$  variation = 0.07mH at 1000Hz, with +/-8mm excursion).

The suspensions use pumaX spiders and low lost NBR surround avoiding any mechanical damping, and keeping constant  $F_s$ [Hz] in large excursion.

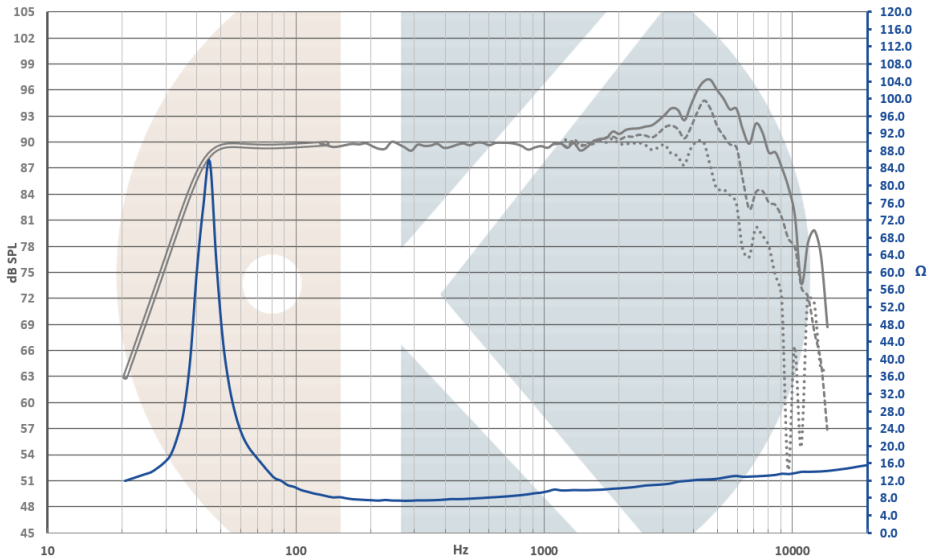

On IEC baffle / Distance: 1m / Signal input: 2,83V / Dash curves: 20° & 40°  
Smoothing: 1/12 Octave / Impedance measured in free air  
Curve below 120Hz is simulated in 25L vented enclosure / Tuning frequency: 44Hz

## Wom180\_vMS

Our products can be adapted to your technical requirements and brand spirit.

[www.Kartesian-acoustic.com](http://www.Kartesian-acoustic.com) - Engineered and produced in France



## Advanced construction

### Membrane

Damped carbon fiber cone  
CNC Aluminum phase lug

### Suspension

Low lost NBR surround  
pumaX spider

### Voice coil:

Ø37mm, 2 layers, CC Aluminum wire  
Glass fiber former

### Motor structure:

Dual Fe magnets (Magnet grade: Y40)  
Long cooper ring  
Optimized and vented pole pieces  
Low carbon steel

### Frame

Injected aluminum (ACD12)  
Fully vented

## T&S

Fs	46Hz
SPL	90dB/2.83V/1m
Re	6.5Ω
Impedance	8 Ω
Qms	4.3
Qts	0.38
Bl	8.1N/A
VAS	21.8L
Mms	14.5g
Sd	136.5cm <sup>2</sup>

Linear excursion: +/-8 mm  
Maximal excursion: +/-12mm

Nominal power: 120W  
*(AES:2012 standard)*

Maximal power handling: 160W

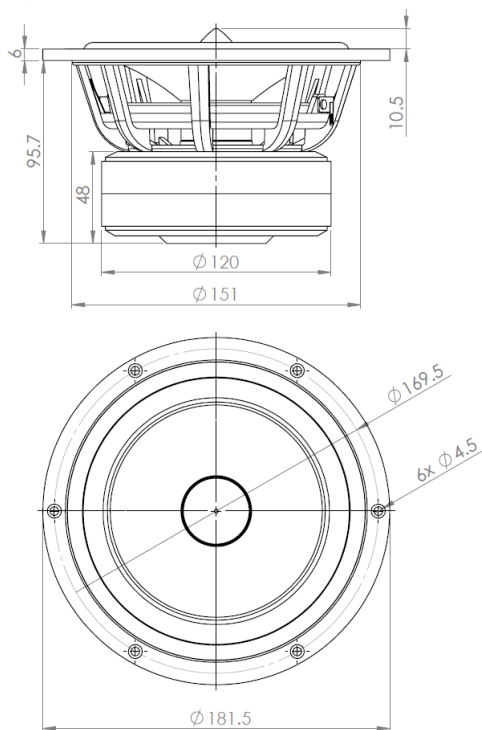

## Integrated innovation



.Konstant Le(X)



.foKus field



.dynamik spider



.Kompliance surround



.Kooling

Visit our website to discover our innovation

## Wom180\_vMS

Our products can be adapted to your technical requirements and brand spirit.

[www.Kartesian-acoustic.com](http://www.Kartesian-acoustic.com) - Engineered and produced in France



# Wom180\_vMS

